

## 800GbE to 4x200GbE (OSFP to OSFP RHS) breakout Active Copper Cable P/N: GOS-40A801-XXC

### Features

- ✓ Hot-plug OSFP CTHS and OSFP RHS form factor
- ✓ Support 8x 50/100Gb/s PAM4 modulation with 16 pairs
- ✓ Support up to 5m length
- ✓ 100Ohm differential impedance system
- ✓ 3.3V power supply & typical power consumption 2.5W
- ✓ Commercial case temperature range of 0°C to 70°C
- ✓ I2C management

### Applications

- ✓ Infiniband NDR/HDR/EDR
- ✓ Switch / router / HBA
- ✓ Enterprise network
- ✓ Data Center Network
- ✓ Data storage and communication industry

### STANDARDS COMPLIANCE

- ✓ IEEE P802.3ck D3.0
- ✓ QSFP-DD MSA HW Rev 4.1
- ✓ CMIS 4.0
- ✓ ROHS

### Description

Gigalight's ACC(Active Copper Cable) assembly series product provide superior signal integrity performance and reliability, comparing to PCC and AOC, ACC is a re-drive solution which built-in linear equalizer to compensate transmission loss, it is an effective solution with low power, low latency, low cost to help high-speed data centers even AI high-computational applications.

Gigalight's GOS-40A801-XXC cable connects data signals from each of the 16 pairs on the single OSFP end to the qual OSFP RHS ends, each pair operates at data rates of up to 100Gb/s and can be adaptive downward compatibility. The product operates 3.3V power supply and comply with OSFP-MSA and IEEE802.3ck ,it's high performance & cost effective I/O solutions for LAN, HPC and SAN.

The height of OSFP CTHS (Close Top Heat Sink) is fully compliant with OSFP finned top, OSFP RHS(Riding



Heat Sink) also can be called flat top, it's a little bit lower than OSFP CTHS.

• **Block Diagram**

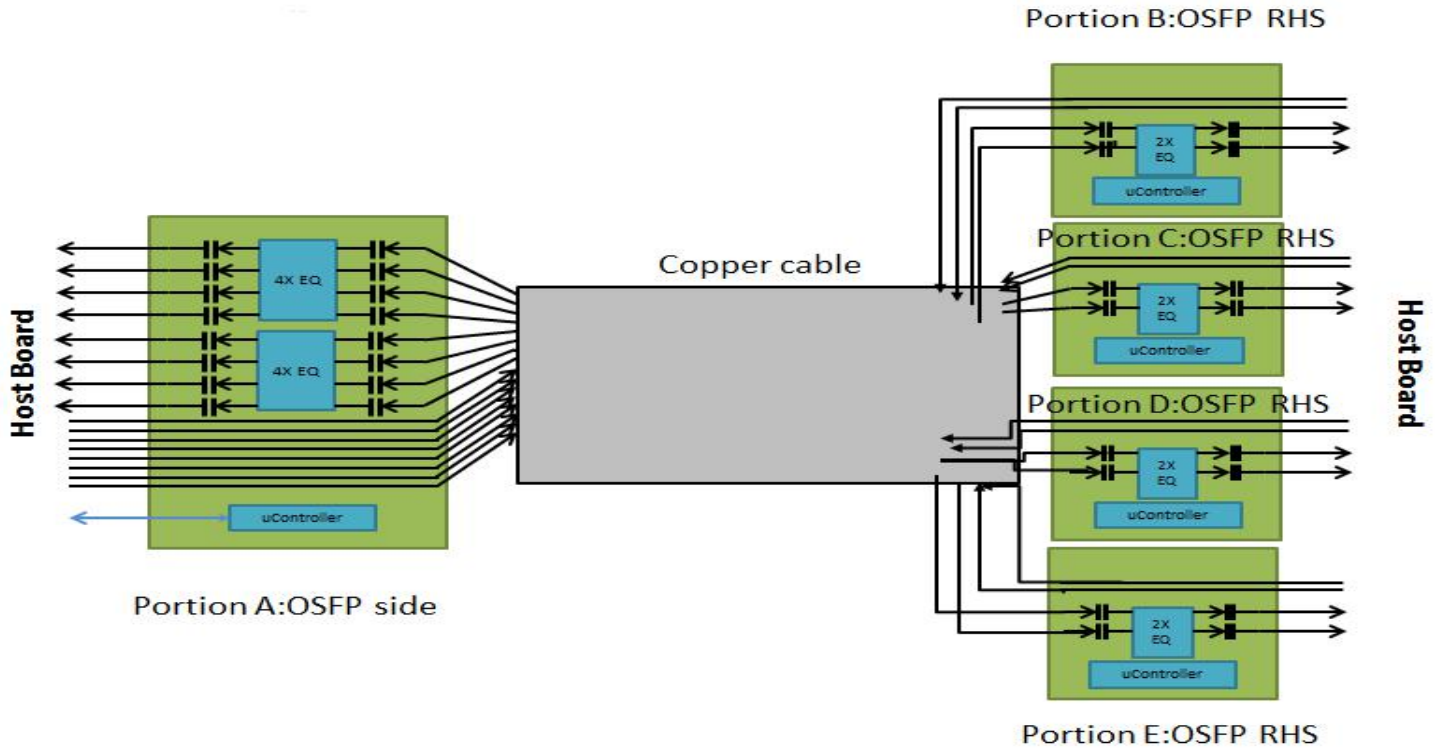

**Absolute Maximum Ratings**

Parameter	Symbol	Min	Max	Unit
Storage Temperature	$T_s$	-20	85	°C
Humidity(non-condensing)	Rh	5	95	%
Supply Voltage	Vcc	-0.3	3.6	V

**Recommended Operating Conditions**

Parameter	Symbol	Min	Typical	Max	Unit
Operating Case Temperature	$T_c$	0		70	°C
Supply Voltage	Vcc	3.13	3.3	3.47	V
Power consumption	Pd		2.5		W
Data Rate per lane(PAM4)	Fd1		53.125		GBaud/s
Data Rate per lane(NRZ)	Fd2	10.3125	53.125		Gbps
Humidity	Rh	5		85	%

## Mechanical Dimensions

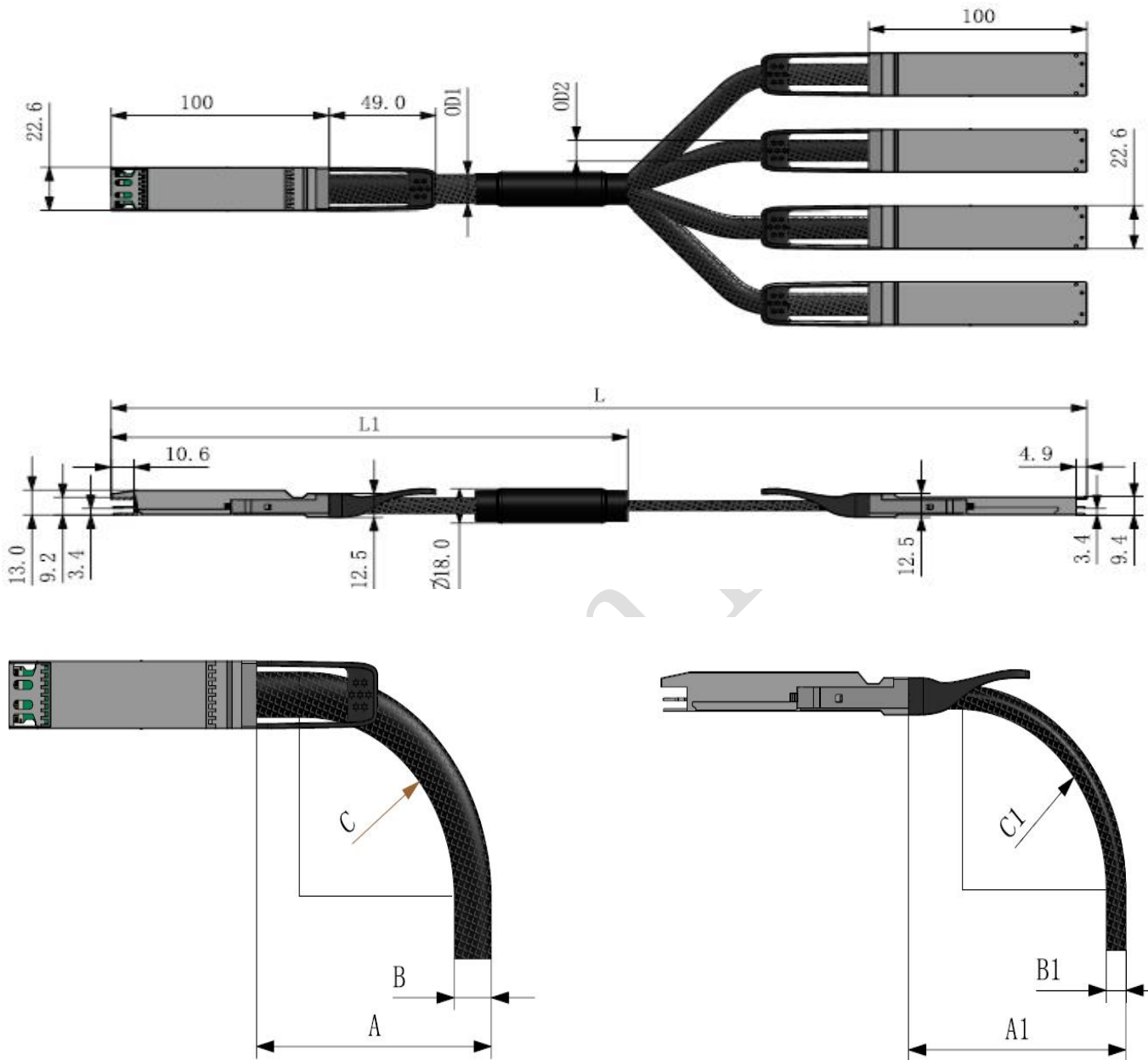

**OSFP Horizontal Direction**

CABLE GAUGE	DIAMETER "B"	MIN BEND RADIUS "C"	MIN BEND RADIUS "A"
26AWG	11MM	55MM	65MM

**OSFP RHS Vertical Direction**

CABLE GAUGE	DIAMETER "B1"	MIN BEND RADIUS "C1"	MIN BEND RADIUS "A1"
26AWG	8MM	40MM	50MM

## OSFP Electrical pinout

Top Side (viewed from top)

60	GND	
59	TX1p	
58	TX1n	
57	GND	
56	TX3p	
55	TX3n	
54	GND	
53	TX5p	
52	TX5n	
51	GND	
50	TX7p	
49	TX7n	
48	GND	
47	SDA	
46	VCC	
45	VCC	
44	INT/RSTn	
43	GND	
42	RX8n	
41	RX8p	
40	GND	
39	RX6n	
38	RX6p	
37	GND	
36	RX4n	
35	RX4p	
34	GND	
33	RX2n	
32	RX2p	
31	GND	

Bottom Side (viewed from bottom)

	GND	1
	TX2p	2
	TX2n	3
	GND	4
	TX4p	5
	TX4n	6
	GND	7
	TX6p	8
	TX6n	9
	GND	10
	TX8p	11
	TX8n	12
	GND	13
	SCL	14
	VCC	15
	VCC	16
	LPWn/PRSn	17
	GND	18
	RX7n	19
	RX7p	20
	GND	21
	RX5n	22
	RX5p	23
	GND	24
	RX3n	25
	RX3p	26
	GND	27
	RX1n	28
	RX1p	29
	GND	30

----- Module Card Edge -----

## Electrical pin list and description

Pin#	Symbol	Description	Logic	Direction	Plug Sequence	Notes
1	GND	Ground			1	
2	TX2p	Transmitter Data Non-Inverted	CML-I	Input from Host	3	
3	TX2n	Transmitter Data Inverted	CML-I	Input from Host	3	
4	GND	Ground			1	
5	TX4p	Transmitter Data Non-Inverted	CML-I	Input from Host	3	
6	TX4n	Transmitter Data Inverted	CML-I	Input from Host	3	
7	GND	Ground			1	
8	TX6p	Transmitter Data Non-Inverted	CML-I	Input from Host	3	
9	TX6n	Transmitter Data Inverted	CML-I	Input from Host	3	
10	GND	Ground			1	
11	TX8p	Transmitter Data Non-Inverted	CML-I	Input from Host	3	
12	TX8n	Transmitter Data Inverted	CML-I	Input from Host	3	
13	GND	Ground			1	
14	SCL	2-wire Serial interface clock	LVC MOS-I/O	Bi-directional	3	Open-Drain with pull-up resistor on Host
15	VCC	+3.3V Power		Power from Host	2	
16	VCC	+3.3V Power		Power from Host	2	
17	LPWn/PRSn	Low-Power Mode / Module Present	Multi-Level	Bi-directional	3	See pin description for required circuit
18	GND	Ground			1	
19	RX7n	Receiver Data Inverted	CML-O	Output to Host	3	
20	RX7p	Receiver Data Non-Inverted	CML-O	Output to Host	3	
21	GND	Ground			1	
22	RX5n	Receiver Data Inverted	CML-O	Output to Host	3	
23	RX5p	Receiver Data Non-Inverted	CML-O	Output to Host	3	
24	GND	Ground			1	
25	RX3n	Receiver Data Inverted	CML-O	Output to Host	3	
26	RX3p	Receiver Data Non-Inverted	CML-O	Output to Host	3	
27	GND	Ground			1	
28	RX1n	Receiver Data Inverted	CML-O	Output to Host	3	
29	RX1p	Receiver Data Non-Inverted	CML-O	Output to Host	3	
30	GND	Ground			1	
31	GND	Ground			1	
32	RX2p	Receiver Data Non-Inverted	CML-O	Output to Host	3	

Pin#	Symbol	Description	Logic	Direction	Plug Sequence	Notes
33	RX2n	Receiver Data Inverted	CML-O	Output to Host	3	
34	GND	Ground			1	
35	RX4p	Receiver Data Non-Inverted	CML-O	Output to Host	3	
36	RX4n	Receiver Data Inverted	CML-O	Output to Host	3	
37	GND	Ground			1	
38	RX6p	Receiver Data Non-Inverted	CML-O	Output to Host	3	
39	RX6n	Receiver Data Inverted	CML-O	Output to Host	3	
40	GND	Ground			1	
41	RX8p	Receiver Data Non-Inverted	CML-O	Output to Host	3	
42	RX8n	Receiver Data Inverted	CML-O	Output to Host	3	
43	GND	Ground			1	
44	INT/RSTn	Module Interrupt / Module Reset	Multi-Level	Bi-directional	3	See pin description for required circuit
45	VCC	+3.3V Power		Power from Host	2	
46	VCC	+3.3V Power		Power from Host	2	
47	SDA	2-wire Serial interface data	LVC MOS-I/O	Bi-directional	3	Open-Drain with pull-up resistor on Host
48	GND	Ground			1	
49	TX7n	Transmitter Data Inverted	CML-I	Input from Host	3	
50	TX7p	Transmitter Data Non-Inverted	CML-I	Input from Host	3	
51	GND	Ground			1	
52	TX5n	Transmitter Data Inverted	CML-I	Input from Host	3	
53	TX5p	Transmitter Data Non-Inverted	CML-I	Input from Host	3	
54	GND	Ground			1	
55	TX3n	Transmitter Data Inverted	CML-I	Input from Host	3	
56	TX3p	Transmitter Data Non-Inverted	CML-I	Input from Host	3	
57	GND	Ground			1	
58	TX1n	Transmitter Data Inverted	CML-I	Input from Host	3	
59	TX1p	Transmitter Data Non-Inverted	CML-I	Input from Host	3	
60	GND	Ground			1	

## Ordering information

Part Number	GOS-40A801-XXC
Length (meter)	2~5
Wire gauge (AWG)	AWG30/26

If length(meter) is decimal, PN should be as GOS-40A801-DXXC, the wire gauge also can be customized. It's recommend to choose Gigalight's OSFP 800G DAC for less than 2m reach.

## Important Notice

Performance figures, data and any illustrative material provided in this data sheet are typical and must be specifically confirmed in writing by Gigalight before they become applicable to any particular order or contract. In accordance with the Gigalight policy of continuous improvement specifications may change without notice.

The publication of information in this data sheet does not imply freedom from patent or other protective rights of Gigalight or others. Further details are available from any Gigalight sales representative.

E-mail: [sales@gigalight.com](mailto:sales@gigalight.com)

Official Site: [www.gigalight.com](http://www.gigalight.com)

## Revision History

Revision	Date	Description
V0	Jun-21-2024	Advance Release.

Preliminary